

TOP VIEW

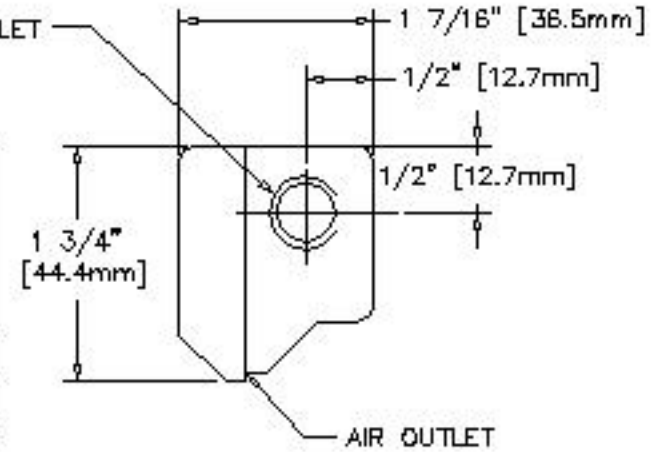

FRONT VIEW



END VIEW

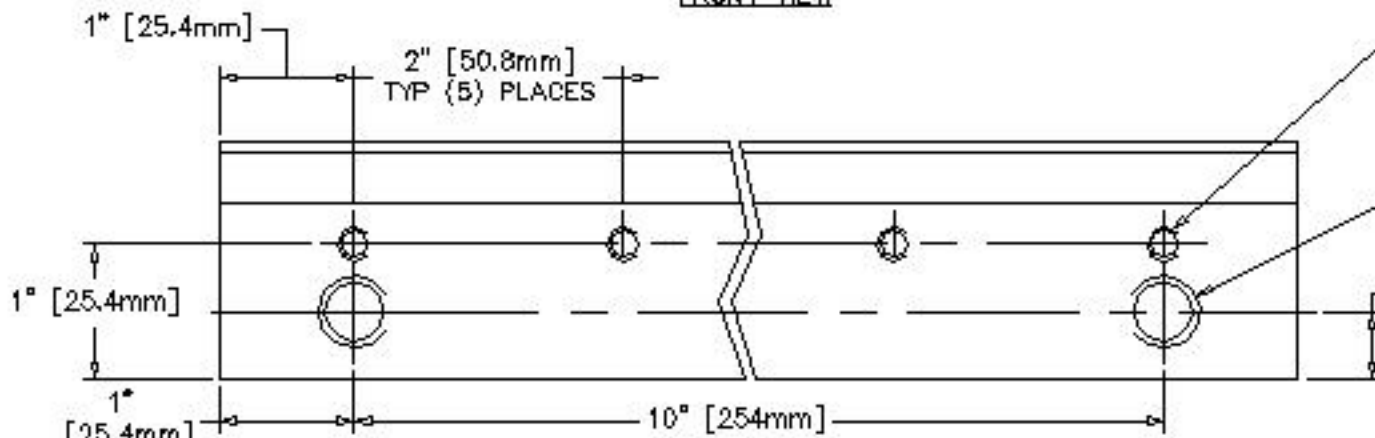

BOTTOM VIEW

1/4-20 TAPPED HOLES AVAILABLE FOR MOUNTING SUPER AIR KNIFE. MAXIMUM THREAD AVAILABLE IS 1/2". NUMBER OF HOLES AVAILABLE IS (8).

1/4-18 NPT AIR INLET  
TYP. (2) PLACES

1/2" [12.7mm]

**EXAIR CORPORATION**

TITLE  
**12" SUPER AIR KNIFE**

DATE  
2/26/98

DRAWING NUMBER  
DIM-110012

SCALE  
1:1

COPYRIGHT 1998- EXAIR CORPORATION